



Innotech Laser – Ihr Partner für Laser-Komponenten und Services  
**Wir bieten Ihnen nicht nur Komponenten, sondern Lösungen für Ihre Anwendungen!**

Innotech Laser beschäftigt sich seit mehr als 15 Jahren mit dem Vertrieb von Lasersystem-Komponenten. Unsere Produkte werden in vielen Bereichen der Industrie, Fertigung und auch in der Medizintechnik eingesetzt. Wir bieten Ihnen qualitativ hochwertige Produkte zu einem fairen Preis-Leistungs-Verhältnis, erstklassigen Service, hochverfügbare Logistik und umfassende, kompetente Beratung zu Lasersystemen und Komponenten. Durch die enge Zusammenarbeit mit dem Hersteller sind wir in der Lage, für Sie maßgeschneiderte Lösungen zu realisieren.

Innotech Laser ist kontinuierlich gewachsen. Dies ist sicherlich auch eine Folge unserer Unternehmensphilosophie, die auf Werten wie Engagement, Wertschätzung und Respekt basiert. Auch ist es unser Anspruch, durch sinnvollen Umgang mit Ressourcen die Umwelt zu schonen.

Optical Lenses	1-8
Amada	9-10
Bystronic	11-12
Empower	15-20
Mazak	21-22
Mitsubishi	23-24
Precitec	25-30
Prima	31-32
Tanaka	33-34
Trumpf	35-36
Others	37-38



■ Optical Components-Fiber Laser Cutting

Fiber laser cutting system is generally used for cutting metal or non-transparent materials with medium or high power laser. The general optical path system and beam transmission sequence are: collimating and expanding the laser from laser QBH or other types of transfer joint through collimating lens to make it parallel light. Then the parallel light is focused at the working position by using the focusing lens. At the same time, there is a protective lens behind the collimating and focusing lenses to prevent the spatters from damaging the collimating and focusing lenses during the cutting process. In the L-shaped cutting head, a 45 degree lens is placed behind the collimating lens to deflect the collimating beam 90 degrees into the focusing mirror for focusing.



PartName	SHOCKOE P/N	Coating	Diameter	Thickness
Protective Window	CG000001	AR/AR@1030-1090nm	21.5	2
	CG000002		22.35	4
	CG000003		24	
	CG000004		24.7	2
	CG000005		24.9	5
	CG000006		25	2
	CG000007		25	
	CG000008		25.4	
	CG000009		25.4	5
	CG000010		27.9	
	CG000011		29.7	4.
	CG000012		30	.5
	CG000013		30	
	CG000014		30	
	CG000015		30	5
	CG000016		32	2
	CG000017		32	5
	CG000018		33	.5
	CG000019		34	
	CG000020		34	
	CG000021		35	5
	CG000022		35	
	CG000023		36	
	CG000024		37	
	CG000025		38.	5
	CG000026		38.	6.35
	CG000027		38	2
	CG000028		40	2
	CG000029		40	3
	CG000030		40	
	CG000031		42	
	CG000032		48	
	CG000033		50	5

Part Name	SHOCKOE P/N	Coating	Diameter	Focal Length
Fused Silica Collimating Lens	CLO00001	AR/AR@1030-1090nm	24	100
	CLO00002		24.7	100
	CLO00003		25	100
	CL. 00004		25.4	75
	CLO00005		25.4	100
	CL. 00006		26	75
	CLO. 0007		28	60
	CLO00008		28	63
	CLO00009		28	75
	CLO00010		28	100
	CLO00011		30	75
	CLO00012		30	100
	CLO00013		37	100
	CLO00014		38.	100
	CLO00015		42	00
Fused Silica Focusing Lens	FLO000001	AR/AR@1030-1090nm	24	120
	FL0000002		24.	125
	FL0000003		24.7	150
	LO000004		25	120
	FL0000005		25.4	125
	FL0000006		25.4	150
	FL0000007		26	150
	FL0000008		28	125
	FL0000009		28	150
	FL0000010		28	200
	FL0000011		30	125
	FL0000012		30	128
	FL0000013		30	150
	FL0000014		30	155
	FL0000015		30	190.5
	FL0000016		30	200
	FL0000017		37	125
	FL0000018		37	150
	FL0000019		37	200
	FL0000020		38.	125
	FL0000021		38.	150
	FL0000022		38.	200
	FL0000023		42	150
	FL0000024		42	200

■ Optical   Components-Fiber   Laser   Welding



Fiber laser welding system is generally used for welding metal or non-transparent materials with medium or high power. The general optical path system and beam transmission sequence are: collimating and expanding the laser from laser QBH or other types of transfer joint through collimating lens to make it parallel light. Then the parallel light is focused at the working position by using the focusing lens. At the same time, there is a protective lens behind the collimating and focusing lenses during the welding process. In the L-shaped cutting head, a 45 degree lens is placed behind the collimating lens to deflect the collimating beam 90 degrees into the focusing lens for focusing. The galvanometer scanning system is turned collimated parallel light incident to the galvanometer and then focused on the working surface through the field lens.

Part Name	SHOCKOE P/N	Coating	Diameter	Thickness
Protective Window	CG0000034	AR/AR@1030-1090nm	18	2
	CG0000035		20	2
	CG0000036		20	3
	CG0000037		27	2
	CG0000038		28	2
	CG0000039		46	2
	CG0000040		36	2
	CG0000041		50	2
	CG0000042		50	
	CG0000043		55	1.5
	CG0000044		53	2
	CG0000045		75	2
	CG0000046		93	3
	CG0000047		96	3
	CG0000048		113	3
CG0000049	120	5		
CG0000050	134	3		

PartName	SHOCKOE P/N	Coating	Diameter	Focal Length
Fused Silica Collimating Lens	CL0000016	AR/AR@1030-1090nm	38.	100
	CL0000017		38.	125
	CL0000018		38.	150
	CL0000019		38	200
	CLO000020		50	100
	CLO000021		50	125
	CL0000022		50	150
	CL0000023		50	200

Part Name	SHOCKOE P/N	Coating	Diameter	Focal Length
Fused Silica Focusing Lens	FLO000025	AR/AR@1030-1090nm	38.	150
	FLO000026		38.	200
	FLO000027		38.	250
	FLO000028		38.	300
	FLO000029		38.	400
	FLO000030		38.	500
	FLO000031		50	200
	FLO000032		50	250
	FLO000033		50	300
	FLO000034		50	400
	FLO000035		50	500
	FLO000036		50	600
	FLO000037		50	800

### Fixed welded joint optical element

Fixed welding joint optical elements mainly refer to the optical elements used in the fixed welding joint, including collimating lens group, beam combining lens, focusing lens group and protective lens. The collimating lens group mainly realizes the shaping of the light source (divergence becomes parallel), and the focusing lens group mainly realizes the focusing of the beam. The beam combining mirror mainly realizes the beam combining and splitting of laser and monitoring light in processing, and can also realize the beam combining and splitting of multi band laser.



Part Name	SHOCKOE P/N	Coating	Diameter	Focal Length
光纤准直镜	CL0000024	AR/AR@1030-1090	20	50/60/70/100
	CL0000025		30	60/75/100/125
	CL0000026		38	75/100/125/135/150/200
	CL0000027		50	100/120/150/200

PartName	SHOCKOE P/N	Coating	Diameter	Focal Length
光纤聚焦镜	FL0000038	AR/AR@1030-1090	30	100/120/125/150/200/400
	FL0000039		30	100/125/150/200
	FL0000040		38	150/200/250/300/350
	FL0000041		50	150/200/250/300/350

PartName	SHOCKOE P/N	Coating	Product specification
光纤反射镜	FL0000042	HR@1030-1090nm,45° AOI	54mmL*38mmW*5mmT
	FL0000043		80mmL*55mmW*6mmT
光纤合束镜	FL0000044	HR@900-1090nm&AR 45° AOI AR@900-1090nm&HR 45° AOI	54mmL*38mmW*5mmT
	FL0000045		80mmL*55mmW*6mmT

PartName	SHOCKOE P/N	Coating	Product specification
光纤保护片	CG0000034	AR/AR@1030-1090(	30mmD*1.5mmT
	CG0000035		30mmD*2mmT
	CG0000036		37mmD*7mmT
	CG0000037		38mmD*2mmT
	CG0000038		50mmD*2mmT
	CG0000039		55mmD*1.2mmT
	CG0000040		93mmD*3mmT
	CG0000041		113mmD*3mm1
	CG0000042		120mmD*5mmT
	CG0000043		134mmD*3mmT
	CG0000044		146mmD*5mmT
	CG0000045		148mmD*5mmT



Part Name	SHOCKOE P/N	Coating	Product specification
反射镜	SK000006	HR@515-540nm/532 nm.45° AOI	25.4mmD*6mmT
	SK000007		25.4mmD*6.35mm1
	SK000008		30mmD*5mmT
	SK000009		50mmD*10mmT
	SK0000010	HR@355nm&343nm 45° AOI	25.4mmD*6mmT
	SK0000011		25.4mmD*6.35mm1
	SK0000012		25.4mmD*10mm1
	SK0000013		30mmD*5mmT
	SK0000014		50mmD*10mmT

PartName	SHOCKOE P/N	Coating	Product specification
Co <sub>2</sub> 保护膜	SK0000015	AR/AR@10.6um	80mmD*3mm1
	SK0000016		90mmD*3mmT
	SK0000017		90mmD*60mmW*5mm7
	SK0000018		90mmD*64mmW*2.5mm1
	SK0000019		90mmD*70mmW*3mmT

Part Name	SHOCKOE P/N	Coating	Product specification
反射镜	SK000001	HR@10.6um.45° AOI	25.4mmD*3mmT
	SK000002		30mmD*4mmT
	SK000003	HR@1030-1090nm.45° AOI	25.4mmD*6.35mm1
	SK000004		30mmD*5mmT
	SK000005		50mmD*10mmT

Part Name	SHOCKOE P/N	Incident spot	Material	Product specification
振镜片	SK0000020	30	硅	53.5mmL*36mmW *4mmT-X 66mmL*44.5mmW *4mmT-y
	SK0000021	30	熔石英/硅	
	SK0000022	30		
	SK0000023	30		
	SK0000024	20		36mmL*25.5mmW *3.5mmT-X 46.5mmL*30.6mmW *3.5mmT-Y
	SK0000025	20		
	SK0000026	20		25mmL*18mmW *2.5mmT-X 32mmL*21mmW *2.5mmT-Y
	SK0000027	14		
	SK0000028	14		
	SK0000029	14		



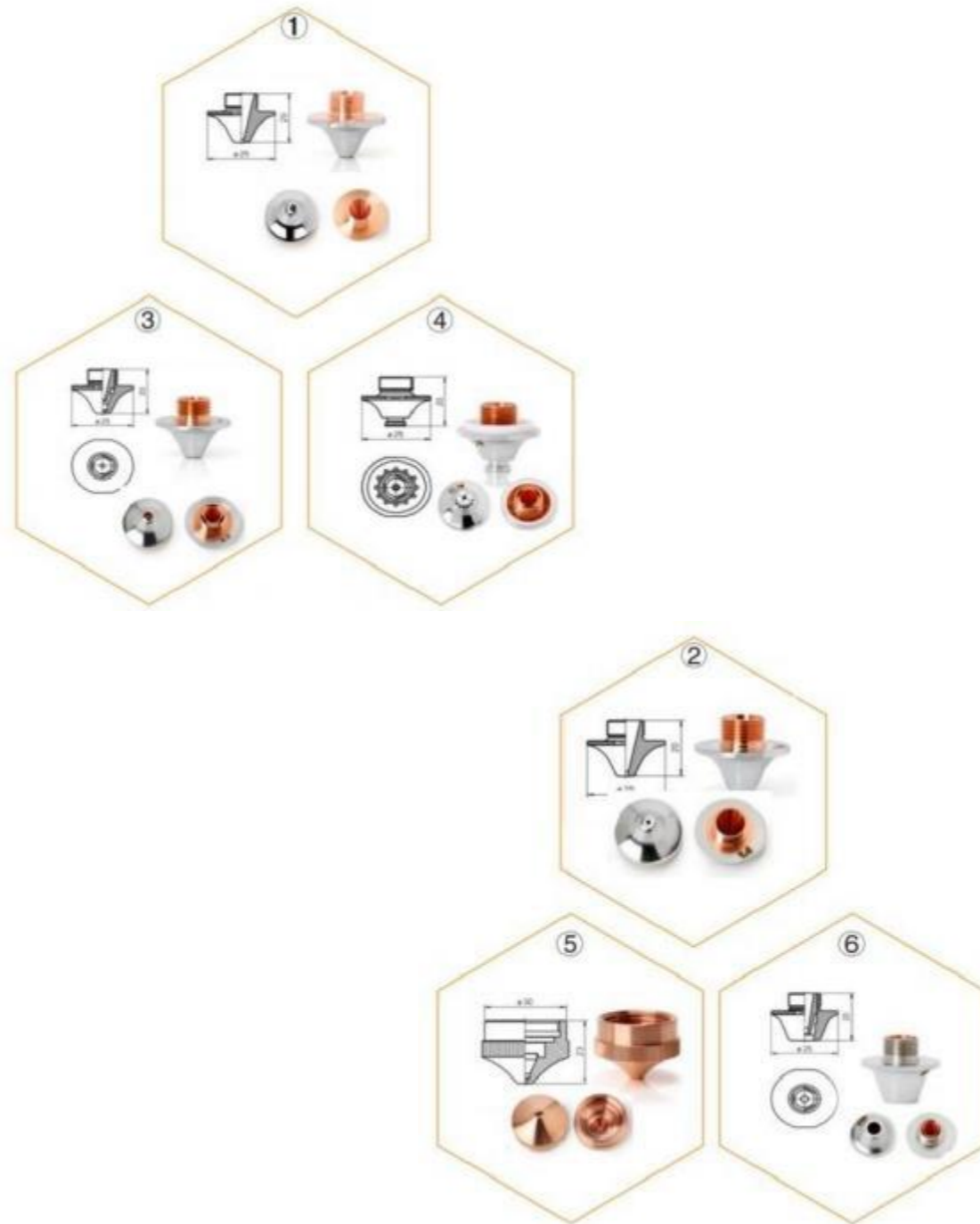

Part	SHOCKOE P/N	DESCRIPTION
	NZAM0001	Amada Single - Hole Flared Mushroom Nozzle
2	NZAM0002	Amada @ Single - Hole CP Flared Mushroom Nozzle
3	NZAM0003	Amada Double Mushroom Nozzle
4	NZAM0004	Amada Double WACS CP Nozzle
5	NZAM0005	Amada Nozzle Protective Outer
6	NZAM000	mada Clean - Cut Nozzle
7	CBAM0001	mada Sensor cable,305 mm(12")71341630
8	CBAM0002	Amada Sensor cable HS-5,305 mm(12")premium,armored71398293
9	CBAM0003	Amada Sensor cable,305mm(12")71398965,71517359
10	CBAM0004	Amada Sensor cable,305 mm(12")premium,armored71398965,71341901
11	CBAM0005	Amada Sensor cable,230 mm(8")premium71369851



Part	SHOCKOE P/N	DESCRIPTION
	NZBY0001	Bystronice HK Nozzle
2	NZBY0002	Bystronic@HK Nozzle(Chromed )
3	NZBY0003	Bystronic● HK Nozzle
4	NZBY0004	Bystronic● HK Nozzle(Chromed )
5	NZBY0005	Bystronic● NK Double Nozzle
6	NZBY0006	Bystronic● NK Double Nozzle (Chromed )
7	NZBY0007	Bystronic● 35H Nozzle
8	NZBY0008	Bystronic Highyag Nozzle Connector
9	NZBY0009	3ystronic@New Nozzle Connector #10083263
10	NZBY0010	Bystronico Fiber Laser Nozzle Connector #10064099
11	NZBY0011	Bystronic Nozzle Body (External Thread)#2-08701
12	NZBY0012	Bystronic@Nozzle Body #10032930
13	NZBY0013	Bystronic Nozzle Body #2-10837



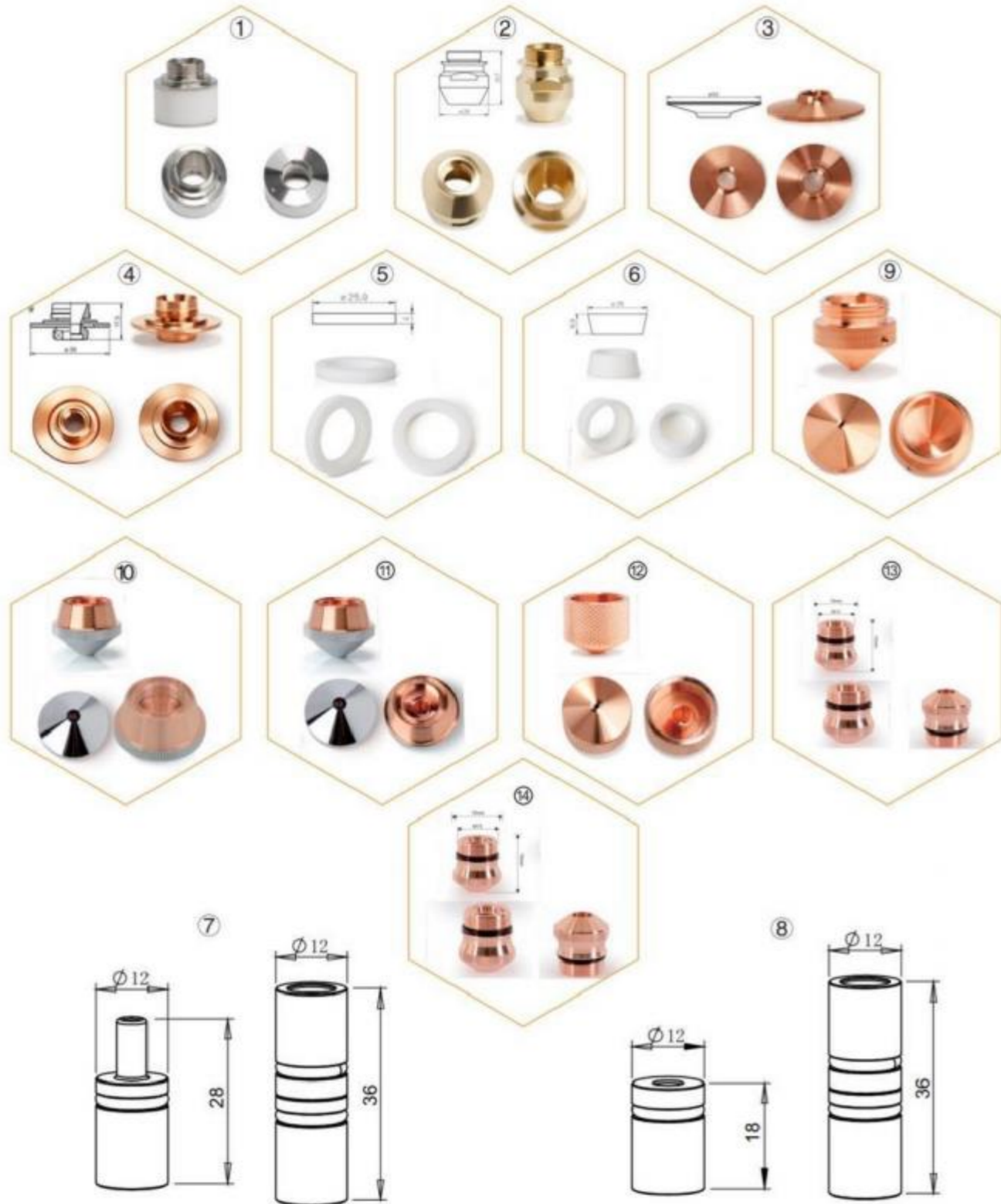

Part	SHOCKOE P/N	DESCRIPTION
	NZBY0014	BystronicHighyag Ceramic Nozzle Holder
	NZBY0015	BystronicNozzle Holder #10034061
	NZBY0016	BystronicThreaded Signboard #2-08700
4	NZBY0017	Bystronic●Nozzle Adantor#10051133
5	CHBY 0001	BystronicCeramic InsulatingDisc #4-01642
6	CHBY0002	Bystronic●Ceramic Cone #4-01959
7	SPBY 0001	Bystronic● Water connector,male #7023207
8	SPBY 0002	Bystronic Water connector,female #7023208
9	NZDNO00	DNENozzle
10	NZDNO002	DNESingle Nozzle
11	NZDNO003	DNEDouble Nozzle
12	NZDNO004	DNE@Old Nozzle
13	NZDNO00E	DNE@New Single Nozzle
14	NZDNO006	DNENew Double Nozzle



Part	SHOCKOE P/N	DESCRIPTION
	NZIQ0001	Raytools Regular Single Nozzle
2	NZIQ0002	Raytools Regular Double Nozzle CP
3	NZIQ0003	Raytools ● Regular Sharp Single Nozzle
	NZIQ0004	Raytools Regular Sharp Double Nozzle
	NZIQ0005	RaytoolsHi-Speed Single Nozzle
	NZIQ0006	Raytools Hi-Speed Double Nozzle
	NZIQ0007	Raytools NomContact Single Nozzle
	NZIQ0008	Raytools Nor-Contact Double Nozzle
	NZIQ0009	RaytoolsTipRetainer Nut
10	NZIQ0010	RaytoolsNozzle Body
11	NZIQ0011	Raytools 3D M6 Nozzle
12	NZIQ0012	Raytools●3D MB Single Nozzle
13	NZIQ0013	Raytools3D M8 Double Nozzle



Part	SHOCKOE P/N	DESCRIPTION
	NZIQ0014	Raytools Bodor Hexagona Single Nozzle30mm
2	NZIQ0015	Raytools Bodor Hexagona Double Nozzle 30 mm
3	CHJQ0001	RaytoolsCeramic Nozzle Holder32 mm
4	CHJQ0002	Raytools3D Ceramic Nozzle Holder195 mm
5	SPLR0001	Raytools Ceramic Lock Ring BT240S
6	CBJQ0001	Raytools TTW SMB+SMA Sensor Cable#211TTW9012
7	TRAJQ001	Raytools BT210S Sensor Assembly
8	TRAJQ002	Raytools BT240S Sensor Assembly
9	TRAJQ003	Raytools BM109 Sensor Assembly
10	TRAJQ004	Raytools BM111 Sensor Assembly
11	TRAJQ005	Raytools BM14 Sensor Assembly
12	TRAJQ00	Raytools Lasermech Sensor Assembly





Part	SHOCKOE P/N	DESCRIPTION
	SPCH000	Raytools Collimating Lens Holder BT210S
	SPCH002	Raytools Collimating Lens Holder BT240S
	SPCH003	Raytools Collimating Lens Holder BM109
	SPCH004	Raytools Collimating Lens Holder BM111
	SPCH005	Raytools Collimating Lens Holder BM114
	SPFH001	Raytools Focusing Lens Holder BT210S
	SPFH002	Raytools Focusing Lens Holder BT240S
	SPFH003	Raytools Focusing Lens Holder BM109
9	SPFH004	Raytools Focusing Lens Holder BM111
10	SPFH000	Raytools
11	QBHQ. 0	Raytools Fiber Laser QBH Adaptor
12	SRJQ000	Raytools Seal Ring 30x1.8mm #11021MA120066 BT240S, BM111 BT240S, BM111
	SRJQ002	Raytools Seal Ring 33x1.8mm #11021MA120068 BT240S/BT240S
	SRJQ003	Raytools Seal Ring 32.2x2.4mm #11021N2110007 BT240S/BT240S
	SRJQ004	Raytools Seal Ring 33x1.5mm #11021MA320199 BM109/BM109
	SRJQ005	Raytools Seal Ring 38x1.8mm #11021MA120072 BM109/BM109
	SRJQ000	Raytools Seal Ring 35x1.5mm #11021MA320267 BM111/BM111
	SRJQ007	Raytools Seal Ring 42.5mm #11021M2110005 BM114/BM114
	SRJQ008	Raytools Seal Ring 38x1.8mm #11021MA3D20243 BM109 BM114/BM109, BM114
	SRJQ009	Raytools Seal Ring 38x1.8mm #11021MA120072 BM114/BM111
	SRJQ010	Raytools Seal Ring 29.2x21x3.55mm #11021M2110051 BM109 BM111/BM109, BM111
	SRJQ011	Raytools Seal Ring 42x1.8mm #11021MA120075 BM109/BM109
	SRJQ012	Raytools Seal Ring 50x1.8mm #11021MA120078 BM114/BM114

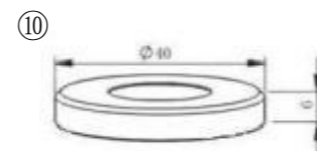
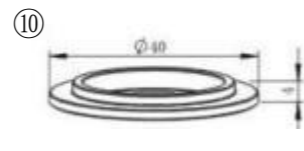
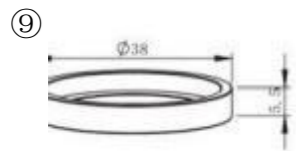
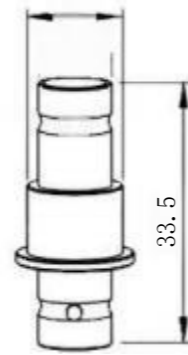

Part	SHOCKOE P/N	DESCRIPTION
	NZMA0001	Mazakslim Single Nozzle
2	NZMA0002	Mazak@Pencil Single Nozzle
3	NZMA0003	Mazak ° Pencil Double Nozzle
4	NZMA0004	MazakDouble Nozzle
5	NZMA0005	Mazak3D Nozzle
6	CBMA0001	MazakSensor cable,short 280mm/long 310mm 46683301980/46683301330
7	CBMA0002	Mazake Sensor cable,305mm /280mm armored 46683301330/46683301980/
8	CBMA0003	Mazak Connecting cable adapter
9	CHMA000	MazakRing,ceramic 46143300270
10	CHMA0002	MazakoRing,ceramic 46143300260C
11	CHMA0003	MazakeRing,ceramic 46143304440

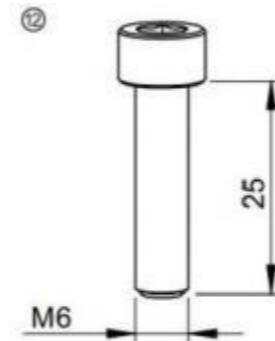
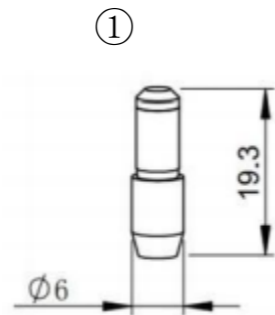
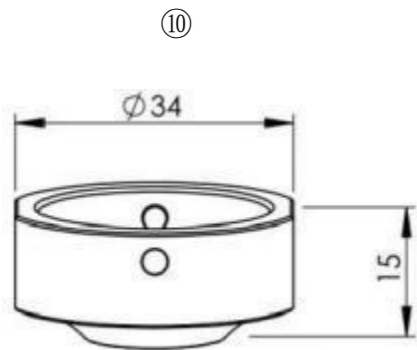
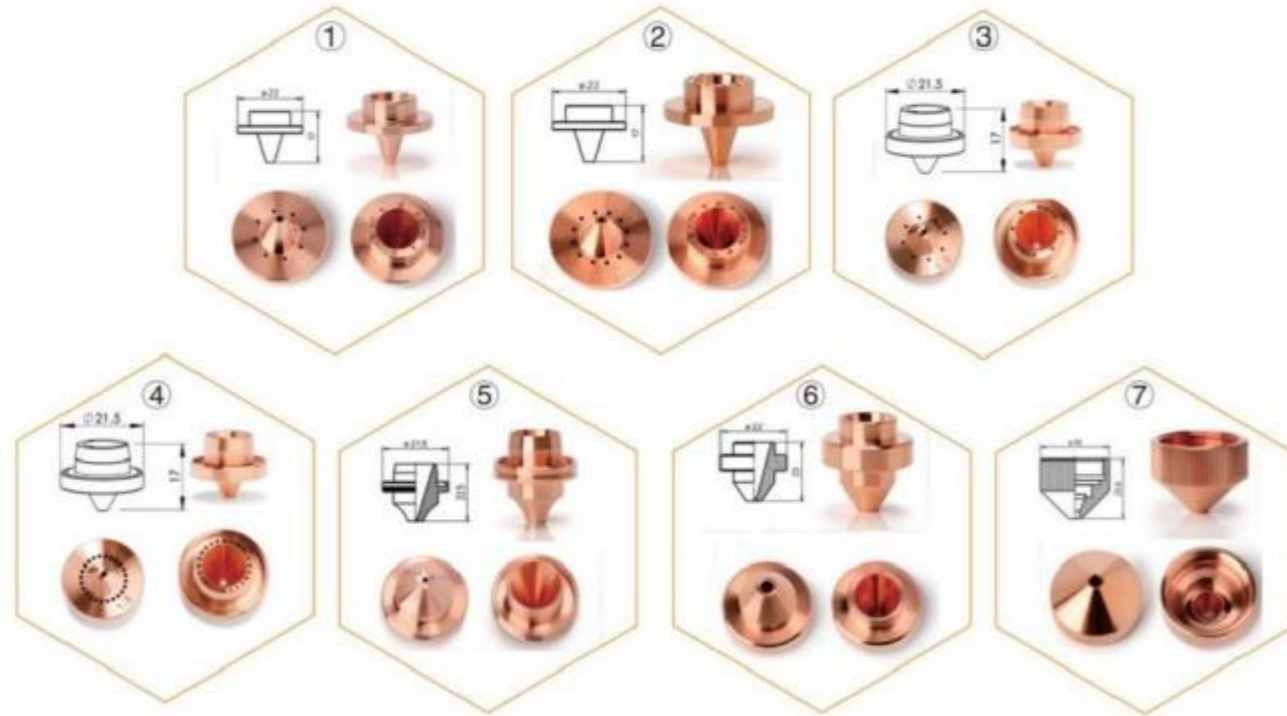

Part	SHOCKOE P/N	DESCRIPTION
	NZMB0001	Mitsubishi 8-Hole Nozzle
2	NZMB0002	Mitsubishi 12-Hole Nozzle
3	NZMB0003	Mitsubishi New Style 8-Hole Nozzle
4	NZMB0004	Mitsubishi New Style 24-Hole Nozzle
5	NZMB0005	Mitsubishi EX Series Nozzle
6	NZMB0006	Mitsubishi ● LVP Nozzle
7	NZMB0007	Mitsubishi Nozzle Shield Cup-Multi Hole Short
8	CHMB0001	Mitsubishi Nozzle holder, EX insulation BQ980D311GO2
9	CHMB0002	Mitsubishi Nozzle holder P0594-860-00001, PHX-INS
10	SPMB0001	Mitsubishi Nozzle EX outer for single MB-nozzle BQ980D328G01
11	SPMB0002	Mitsubishi AM-Safety pin 71800009, P921K000P25
12	SPMB0003	Mitsubishi AM-Safety screw 71800008, L2490A005



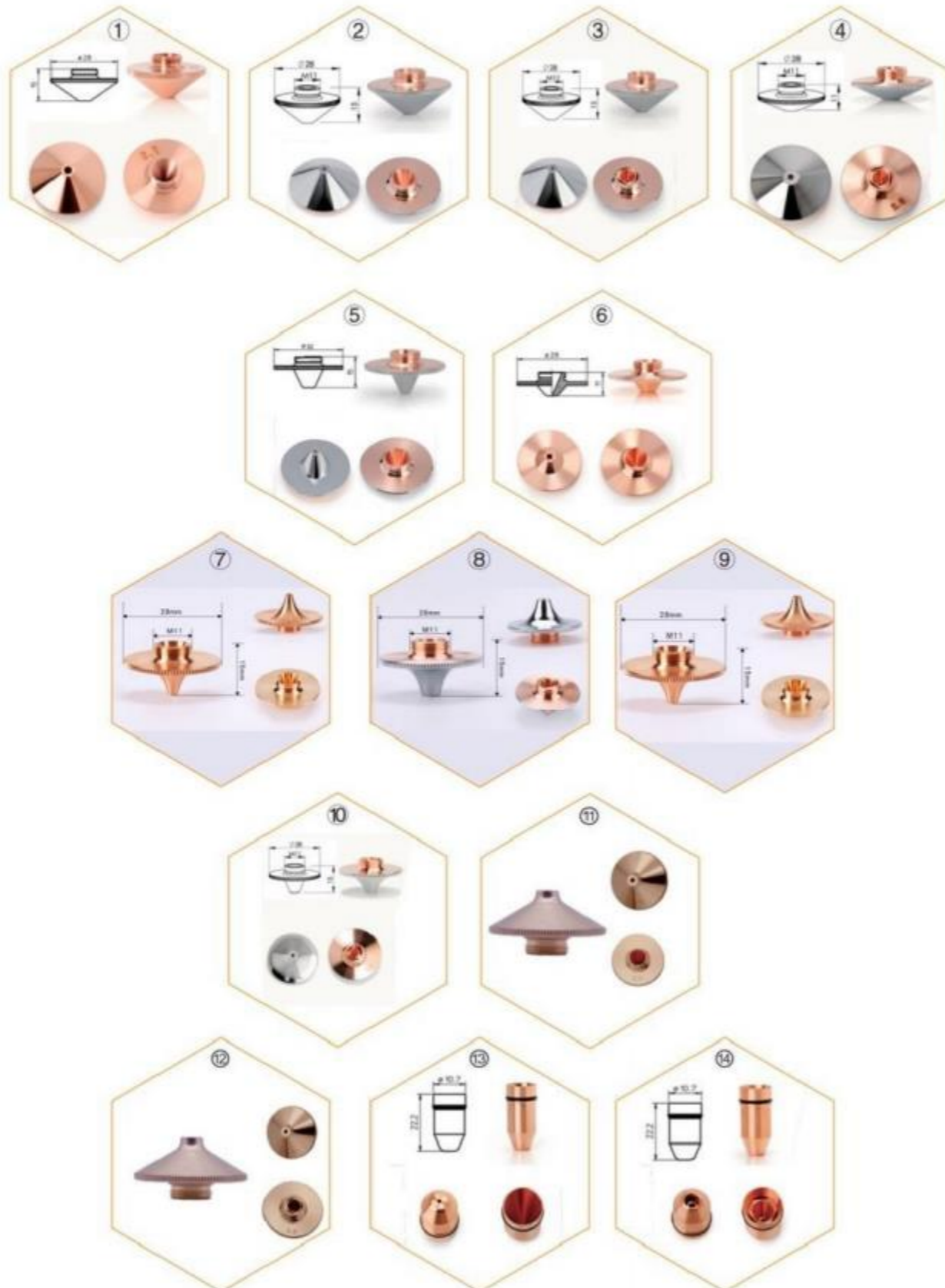

Part	SHOCKOE P/N	DESCRIPTION
	NZPT0001	PrecitecRegular Single Nozzle
2	NZPT0002	Precitec Regular Single NozzleCP
3	NZPT0003	Drecitec●Regular Double NozzleCP
4	NZPT0004	PrecitecShort Double Nozzle
5	NZPT0005	DrecitecRegular Sharp Single Nozzle CP
6	NZPT0006	Precitec° Short Sharp Single Nozzle CP
7	NZPT000;	PrecitechSG Single Nozzle
8	NZPT0008	Precitec●HSG Double Nozzle CP
9	NZPT0009	PrecitechAN SSingle Nozzle
10	NZPT0010	PrecitechAN S Double Nozzle
11	NZPT0011	PrecitecWSX WPCTSingle Nozzle
12	NZPT0012	PrecitecWSX WPCTDouble Nozzle
13	NZPT0013	PrecitecNon-Contact Single Nozzle
14	NZPT0014	Precitec●Non-Contact Double Nozzle



Part	SHOCKOE P/N	DESCRIPTION
	CHPT000	Precitec Ceramic Nozzle Holder KT B2 Con #P0571-1051-00001
	CHPT0002	Precitec Ceramic Nozzle Holder KT B2 Cyl#P0571-260-00001 /281330
3	CHPT0003	Precitec Ceramic Nozzle Holder KT B2 Con
4	CHPT0004	Precitec Ceramic Nozzle Holder KT B2 Con Imported
5	CHPT0005	Precitec Gold Ceramic Nozzle Holder KT B2 Con
6	CHPT0006	Precitec Gold Ceramic Nozzle Holder KT B2 Cyl
7	SPLR0002	WSX Sensor Lock Ring NC 30
8	SPI ROo	Precitec Sensor Lock Ring Procutter/Lightcutter
9	SP000002	WSX Protective Window Drawer
10	SP000003	Precitec@Protective Window Holder
11	SPCHOMO	WSX Collimating Lens Holder NC30
12	SPCHD0	WSX Collimating Lens Holder NC60



Part	SHOCKOE P/N	DESCRIPTION
	SPCH007	Precitec Collimating Lens Holder Lightcutter
	SPCH005	Precitec Collimating Lens Holder Procutter
	SPFH005	WSX Focusing Lens Holder NC 30
	SPFH000	WSX ● Focusing Lens Holder NC 60
	SPFH007	Precitec ● Lens Holder Lightcutter
6	SPFH008	Precitec Focusing Lens Holder Procutter
7	CBPT001	Precitec Sensor Cable KE 500 Z
8	CBPT002	PrecitecHan 's Sensor Cable
	CBPT003	Precitec Two Side Screw Thread Sensor Cable
10	TRAPT001	Precitec Procutter Sensor #P0595-59120-00001
11	TRAPT002	Precitec Procutter Sensor #P0595-60123
12	SRPT001	Precitec Procutter Protective Window 40.4x34x2.7mm
	SRPT002	Precitec Procutter Focusing Seal Ring 60 x53x3mm
	SRPT003	
	SRPT004	● HPSSLFocusing SealRing # HP- C1 / ZZ- B1
	SRPT005	Precitec HPSSL Protective Window Seal Ring #HP-B1/HP-B2/28*4
	SRPT006	recitec ● HPSSLO Ring 22.35*4
13	SRPT007	Precitec WSX Mini Protective Window Seal Ring 25.6mm
	SRPT008	Precitec WSX NC 30 Protective Window Seal Ring 29.8mm



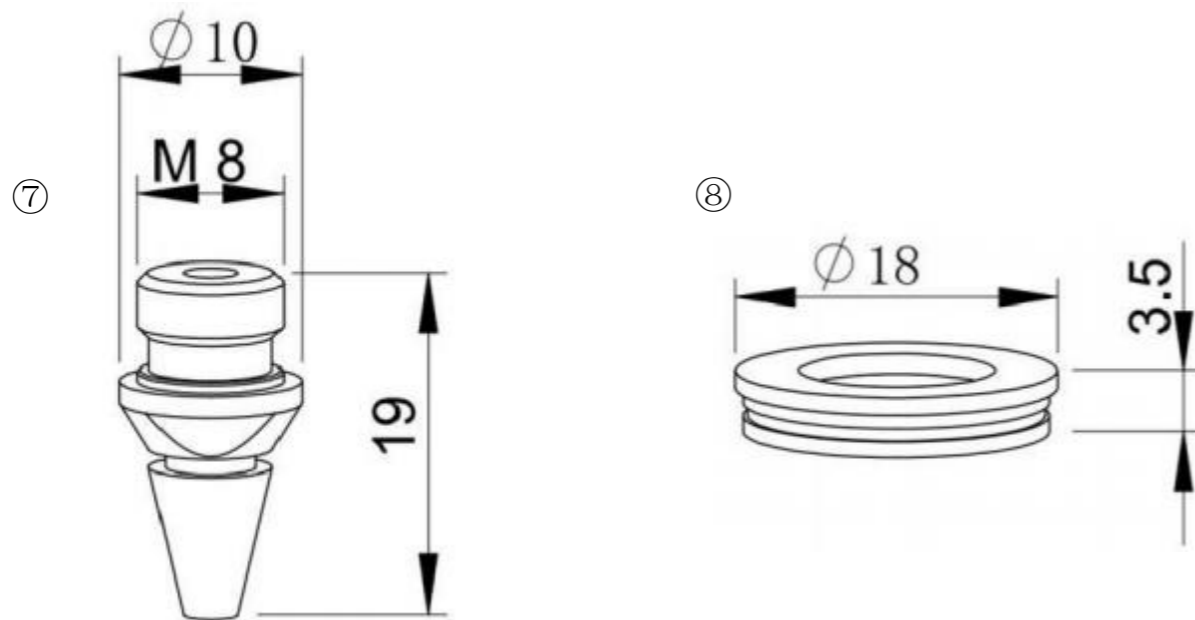
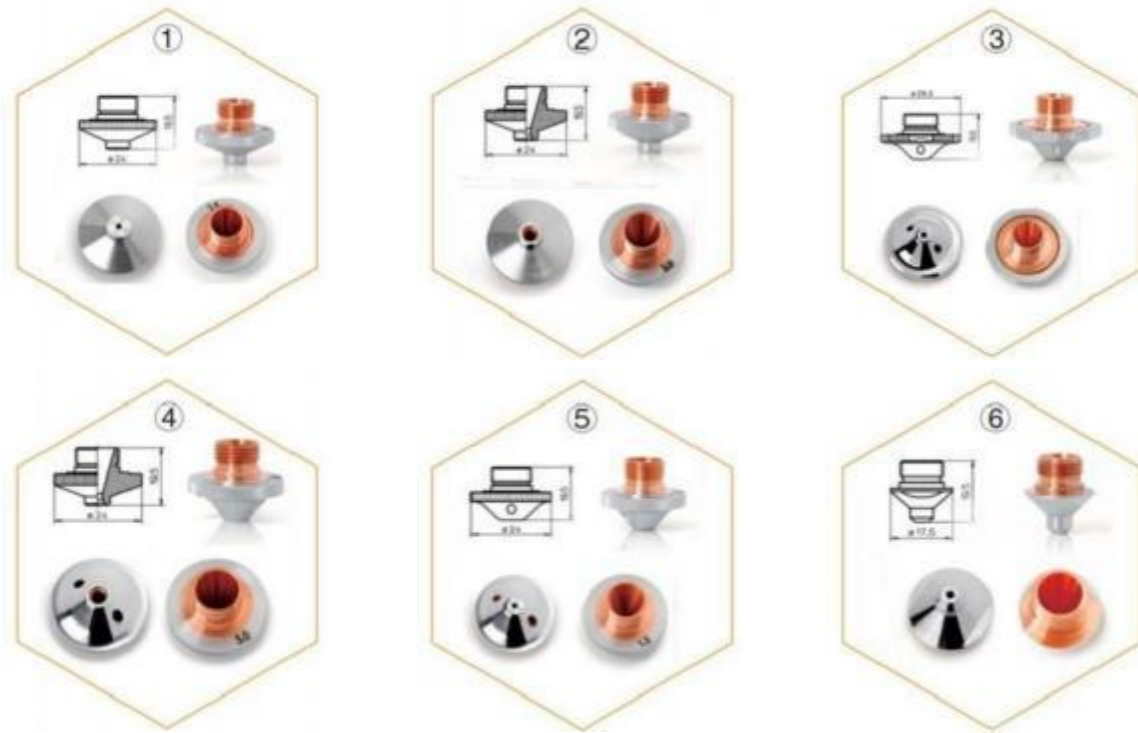

Part	SHOCKOE P/N	DESCRIPTION
	NZPR0001	PrimaSingle Nozzle#LW6.1E.111
	NZPR0002	Prima Single Nozzle#LW6.1G.650
	NZPR0003	PrimaSingle TwoHole Nozzle#LW6.1G.665
	NZPR0004	PrimaSingle TwoHole Nozzle#LW6.1G.650
	NZPR0005	Prima Trumpf Single Two-Hole Nozzle#EAC 5.3
	NZPR0006	Prima° Trumpf Single Nozzle#EAC 5.3
	NZPR0007	PrimaNozzle conical,brass(10 pk)
	SPPR 0001	PrimaInsulating Ring 7.5" Plastic

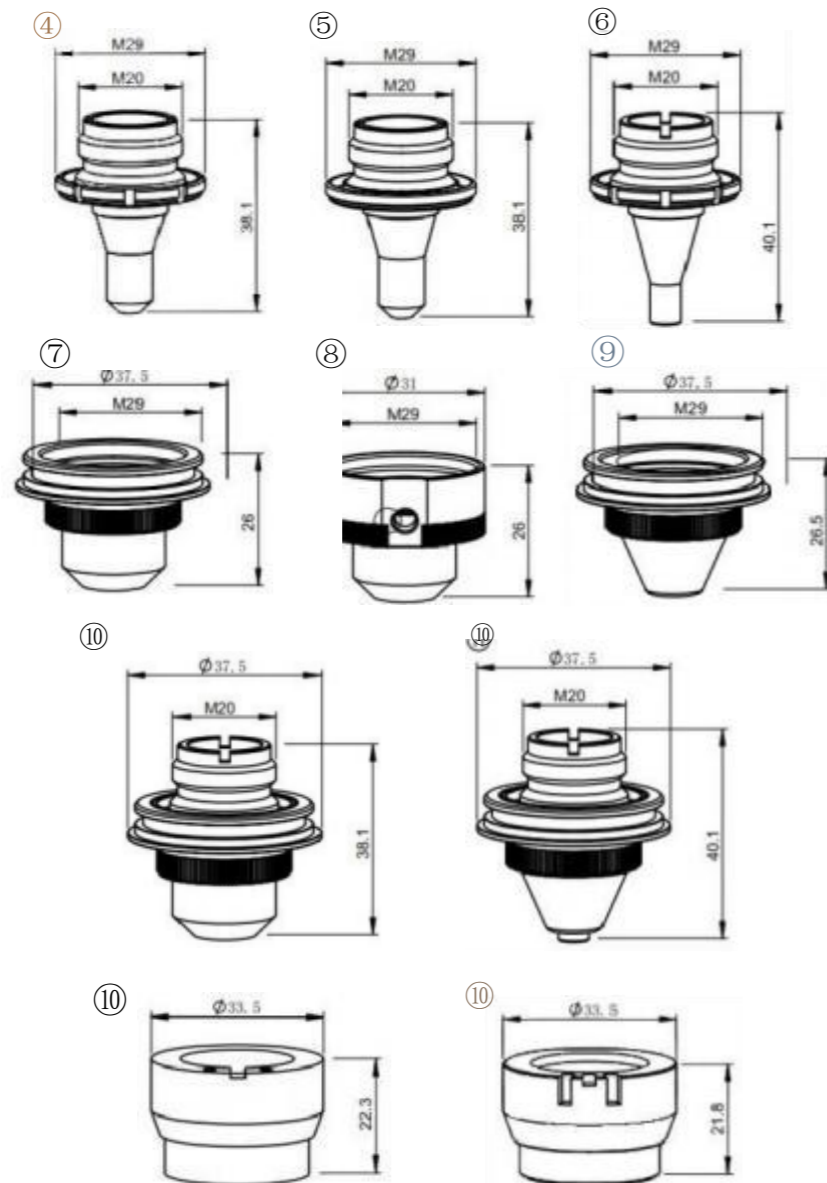

Part	SHOCKOE P/N	DESCRIPTION
	NZTA0001	Tanaka Nozzle #AL283
2	NZTA0002	Tanaka Nozzle #AL381
3	NZTA0003	Tanaka Nozzle #D50
4	NZTA0004	TanakaNozzle inner,2.0mm C20E,A546359
5	NZTA0005	TanakaNozzle inner,2.2mm C22D-1
6	NZTA0006	Tanaka Nozzle bevel inner,2.0mm A546363
7	NZTA0007	Tanaka Nozzle outer C20E
8	NZTA0008	Tanaka Nozzle outer C22D-0
9	NZTA0009	Tanaka ● Nozzle bevel outer
10	NZTA0010	Tanaka ° Nozzle assembly(TK381-C20E-0/AL.283)C20E,A546563
11	NZTA0011	Tanaka Nozzle assembly(TK381-CZ20B-0/AL382 CZ20B-2,A54566
12	CHTA0001	ceram
13	CHTA0002	TanakaNozzle holder ITM 1.5"DZ OEM 281146,PO380-211-00001



Part	SHOCKOE P/N	DESCRIPTION
	NZTM 0001	Trumpf Single Nozzle
2	NZTM 0002	Trumpf Double Nozzle
3	NZTM 0003	Trumpf ● EAA Nozzle
4	NZTM 0004	Trumpf ● EAQ Nozzle
5	NZTM 0005	Trumpf EAU Nozzle
6	NZTM 0006	Trumpf ● EAK Nozzle
7	NZTM 0007	Trumpf ● EAN Nozzle
8	NZTM 0008	Trumpf ● EAC Nozzle
9	NZTM 0009	Trumpf EFL Nozzle
10	NZTM 0010	Trumpf EGL Nozzle
11	NZTN OOL	Trumpf EAV Nozzle
12	NZTM 0012	Trumpf3D Nozzle
13	CHTM 0001	TrumpfCeramic Nozzle Holder #254493/260432
14	CHTM 0002	TrumpfCeramic Nozzle Holder#1349171/1755673
15	CHTM 0003	Trumpf Ceramic Nozzle Holder3D
16	CBTM 0001	Trumpf ●TR-Sensor cable,190 mm(7.5")armored 342474,359983
17	CBTM 0002	TrumpfTR-Sensor cable,432 mm(17")227833
18	CBTM 0003	Trumpf Sensor cable,152 mm(6")armored 280930





Part	SHOCKOE P/N	DESCRIPTION
	NZHK0001	lankwangSingle Nozzle
2	NZHK0002	HankwangDouble Nozzle
3	NZHK0003	lankwang Ceramic Nozzle Holder
4	NZKO0001	KoikeNozzle
5	CHK0000	KoikeCeramic Nozzle Holder
6	NZLVO00	VDCY Single Nozzle/LVD CY
7	NZLVO002	LVDHD Single Nozzle/LVD HD
8	NZLVO003	VDWS Double Nozzle/LVD WS
9	NZLV0004	LVDDouble Nozzle /LVD
10	CHLVO001	VDCeramic Nozzle Holder #P0380-211-00001 /LVD
11	SPFD000	FriendessTip Transformer Assembly
12	SPFD0002	Friendess Handheld Remote Controller
13	SPCS0001	Cotton Swabs 100 Pcs/bag Small, Large 100
14	SPCS0003	Optics Cleaning Tissue - Booklet
15	SPCS0004	OpticssCleaning Fabric
16	SPFE0001	Filter Element 5 Jnch.10 Jnch/5" .10
17	SPO00007	Laser Safety Goggles
18	SPO00009	ORing
19	SPO00011	Raycus● Fiber Protective Cap
20	SPO00012	Max Fiber Protective Cap